

Virus discovery by assembly of virus-derived small silencing RNAs

Qingfa Wu Ph.D

qingfawu@ucr.edu

*Institute for Integrative Genome Biology
University of California, Riverside*

RNA silencing - A natural immune response against viruses in plants, insects & nematodes

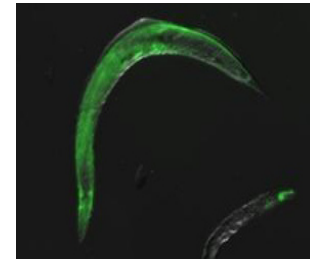

RNA/DNA viruses

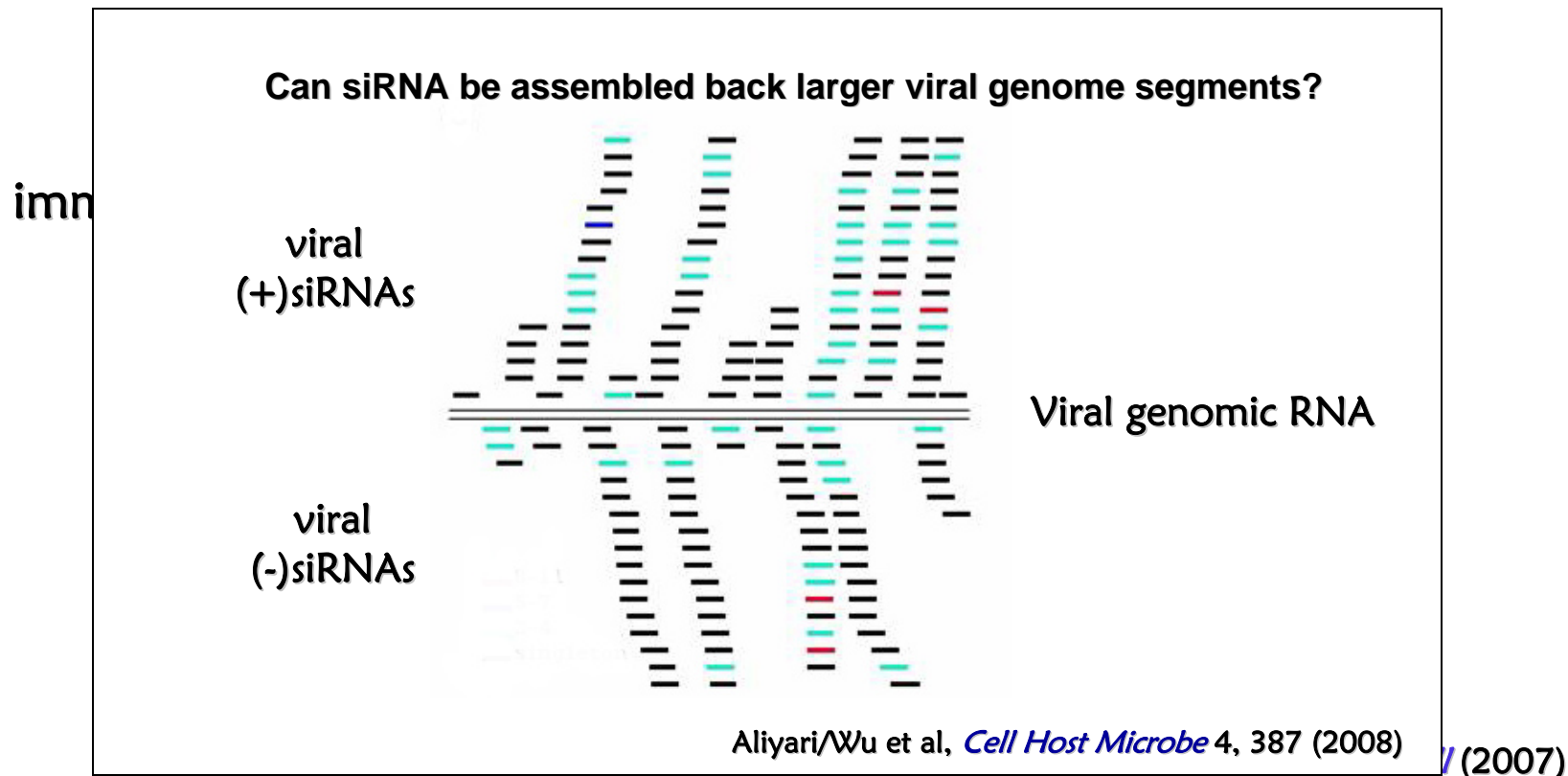

Assembly of virus-derived siRNAs from acute infection hosts



Flock House Virus (FHV)

4,371 reads

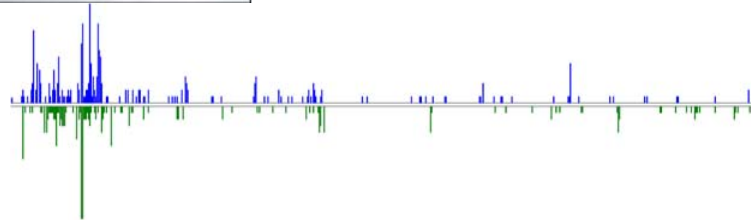

Sindbis virus

3,771,297 reads

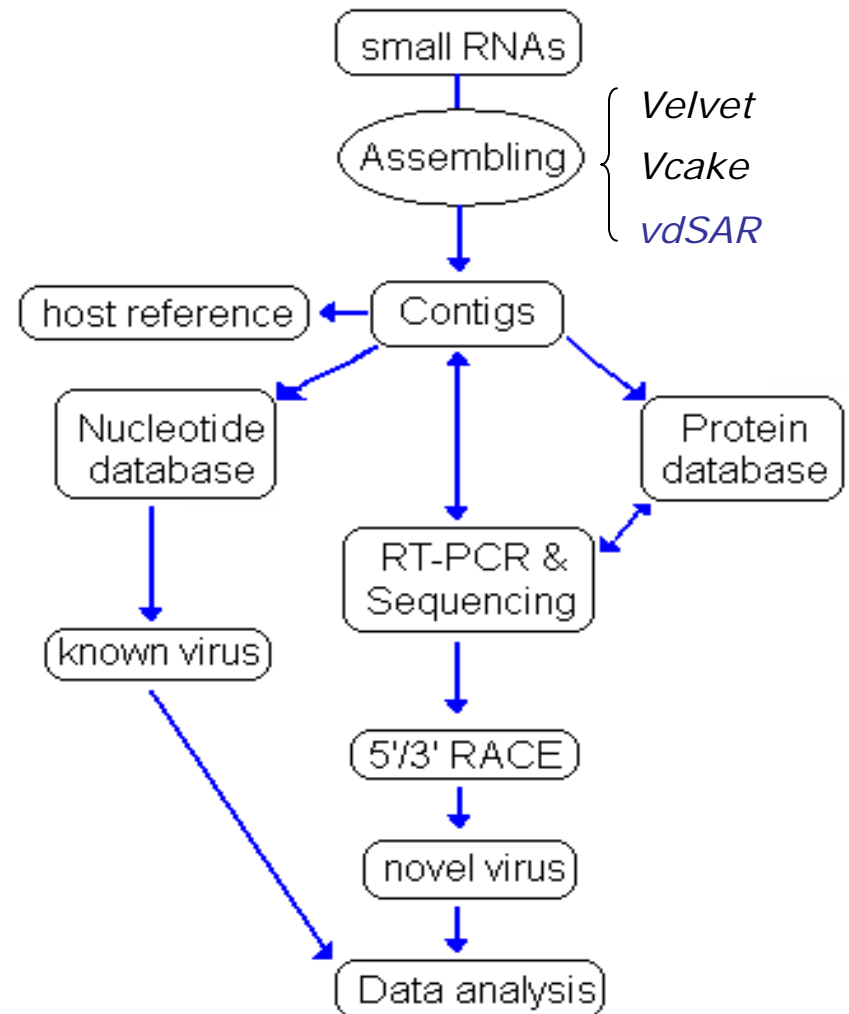
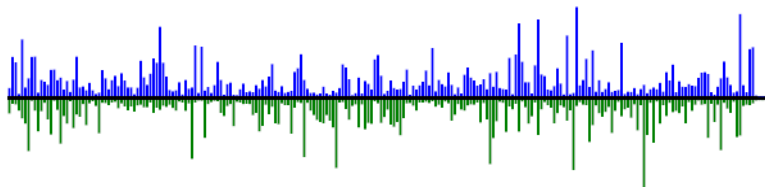

Discovery of viruses from persistent infection *Drosophila* S2 cells

6,454,759 reads => 1639 contigs

Velvet, *k-mer*: 17

1032 contigs => host genome

57 contigs => DXV

49 contigs => ANV

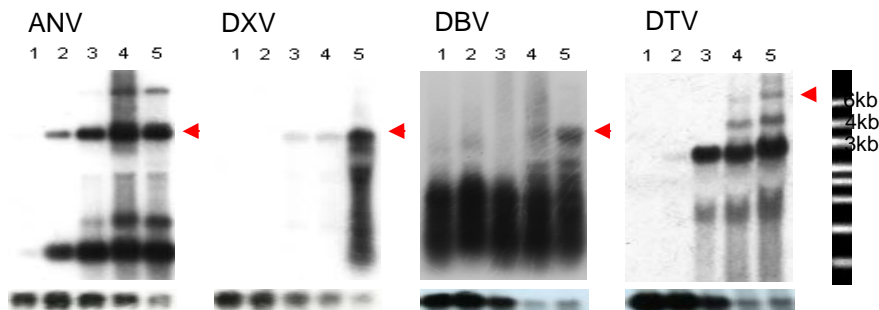
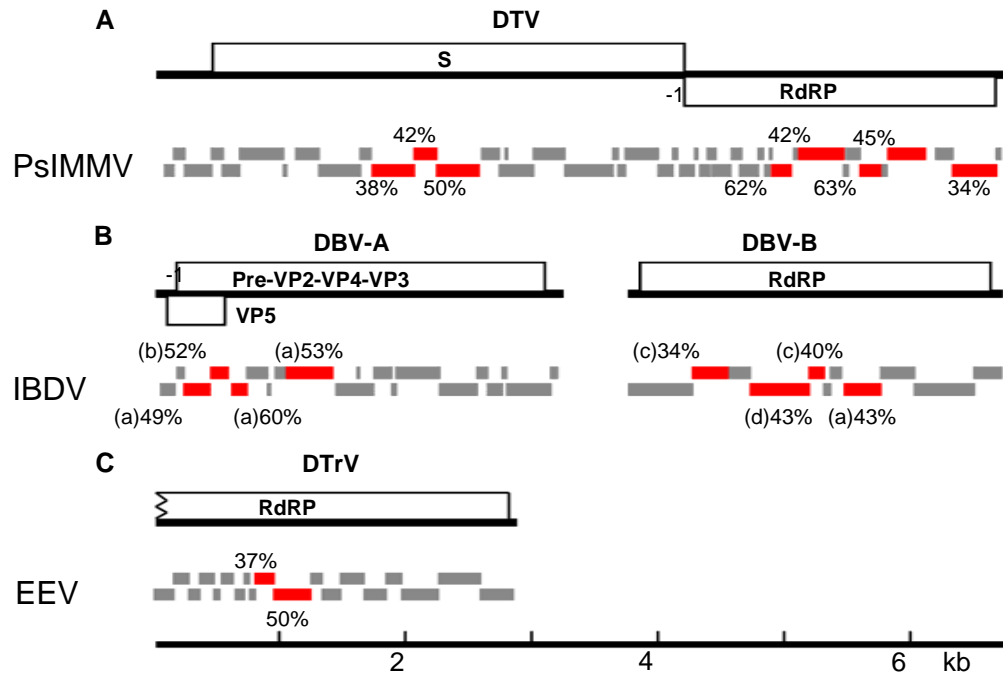

A

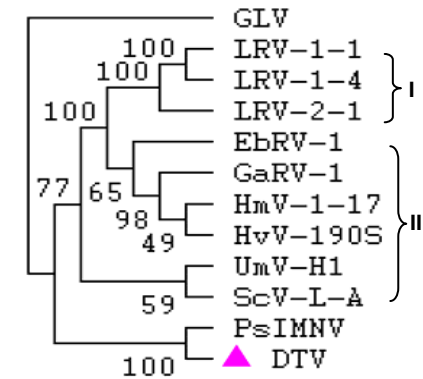

B

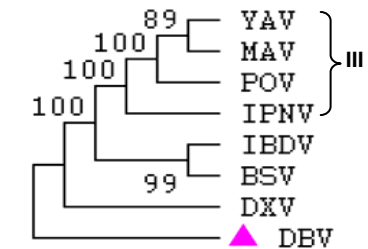

C

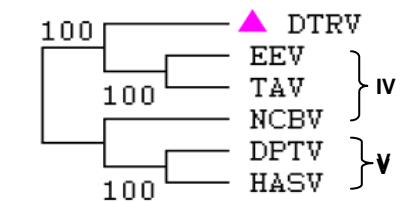

Profiles of viral siRNAs of viruses identified in *Drosophila* S2 cells

DTV
18%

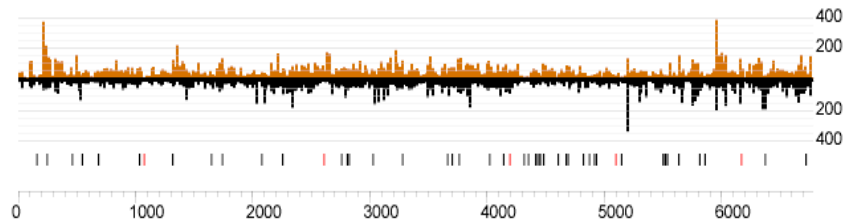

DBV
17%

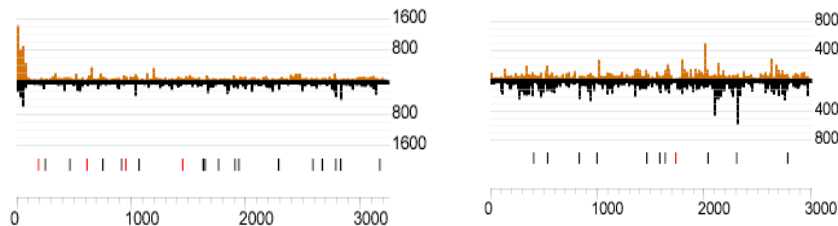

DXV
5.7%

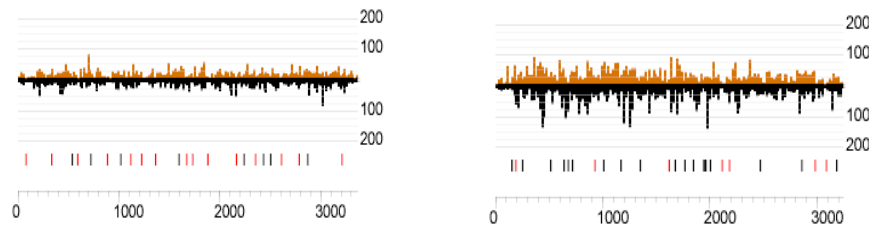

ANV
56%

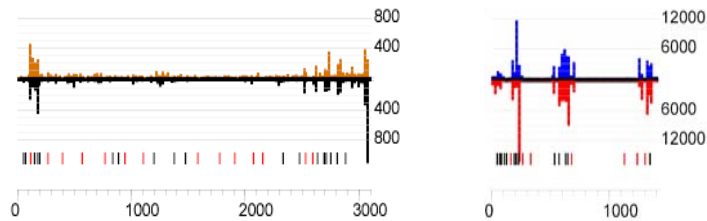

DTrV
3.4%

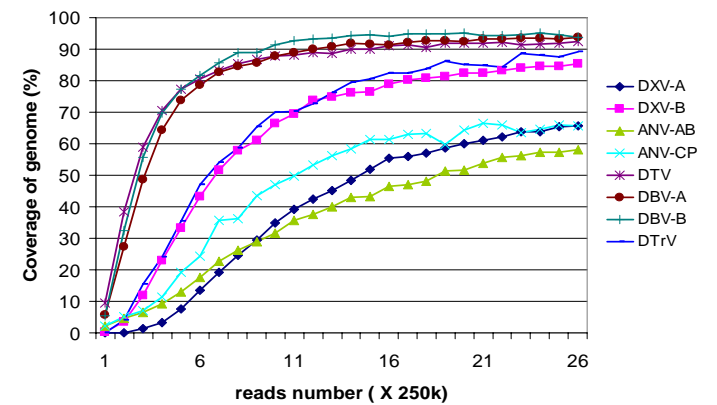
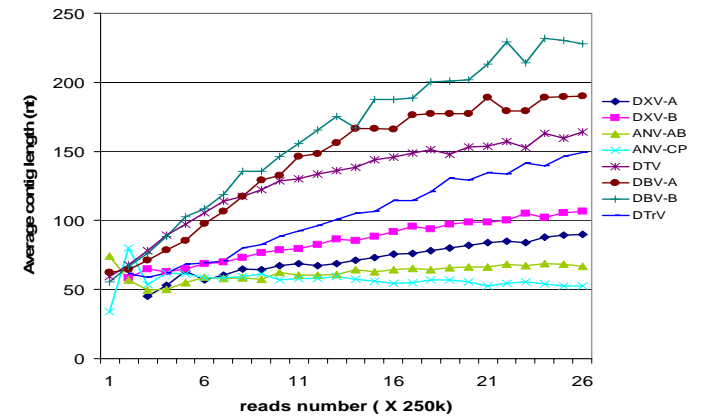
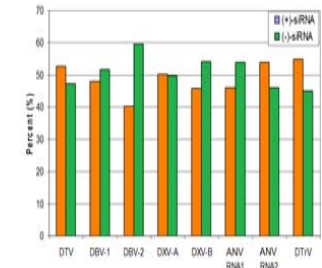
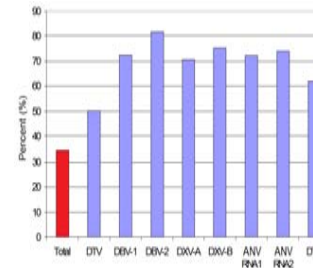
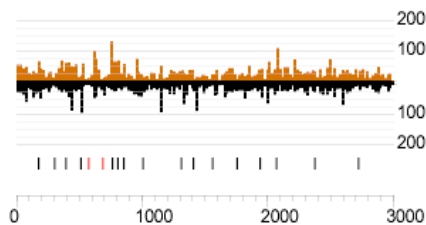

Virus discovery by deep sequencing & assembly of viral siRNAs produced by the host immune system

- **Requires no prior enrichment/purification**
- **Identifies all viruses in one sequencing run**
- **Detects live, replicating viruses**
- **The unique features of small RNAs profiles can be used to develop bioinformatics tools**

Acknowledgement

Shou-Wei Ding (PI)

Xiaohong Wang
Roghiyh Aliyari
Yingjun Luo
Samer Elkashef

Eric Lai (Sloan-Kettering Institute)

Kevin Myles (Virginia Polytechnic Institute and State University)